

MSC OPEN SIGNAL Family

Model MSC-C/V Single Channel Module

NOTE: THIS IS A FACTORY CONFIGURED UNIT

FACTORY CONFIGURATION

Each MSC-C/V unit is configured and calibrated at the factory for the input signal range and voltage output range printed by the factory on the MSC unit's side-label.

The above input signal range is ONE of FIVE ranges the unit is capable of accommodating.. The unit provides a 0 to 5V, 1 to 5V, 0 to 10V, $\pm 5V$, or $\pm 10V$ output signal. Unit re-configuration requires SensorPulse's SignalFlex™ Configuration Utility.

This MSC unit may be reconfigured by a user at any time via their personal computer (PC) or handheld personal computer (HPC) by installing SensorPulse Corp.'s Windows®/PC or Windows®/CE HPC based SignalFlex™ Configurator Utility, interfacing the MSC unit to the computer's RS-232C comm port with an MSF Configuration Cable, and then changing the unit's input/output configuration settings.

OPERATIONAL DESCRIPTION

The MSC family of single channel signal conditioning and isolating modules are intelligent, user programmable, high-accuracy, user friendly, signal conditioning units.

Each MSC model supports one (1) specific analog signal-type on its input channel and outputs one (1) high-level current or voltage signal depending upon model. A diverse MSC model family permits users to select the model which meets their unique signal conditioning needs.

MSC models may be purchased with a factory pre-set configuration for plug-n-play application or custom configured to meet their unique need. All MSC models may be configured/reconfigured by a user at anytime through use of an optional SignalFlex™ Configuration Package.

Theory of Operation - An analog world input signal arriving at the MSC unit is isolated, filtered, amplified, scaled and/or linearized (as required) by the units onboard microprocessor under the direction of the unit's configuration parameters set by the user (or factory) via Windows®/PC or Windows®/CE HPC (Handheld Personal Computer) based SignalFlex™ Configurator Utility.

The conditioned signal is then converted to a high level analog current or voltage output signal (depending upon model) and presented at the unit's isolated output.

REQUIREMENTS

Mandatory:

- 15 - 32VDC, 50mA external supply voltage

Optional:

- SignalFlex™ Configuration Package (Part No. MSF-CC-A1) Package consists of: SignalFlex™ Configurator Utility and MSF Configuration Cable.

INSTALLATION

1. Mount MSC unit on standard TS32 or TS35 DIN rail.
2. See wiring diagram on reverse side. Connect external 15 to 32VDC power source to MSC unit:
Positive (+) to MSC terminal +VDC
Negative (-) to MSC terminal -VDC



3. Connect input current device to MSC unit:
Positive (+) to MSC terminal +C/V IN
Negative (-) to MSC terminal -C/V IN
4. Connect output actuator/device to MSC unit:
Positive (+) to MSC terminal +OUT
Negative (-) to MSC terminal -OUT

DIAGNOSTIC TOOLS

Two LEDs one RED and one GREEN are located on the front face of the MSC's enclosure and provide user with visual indication as to unit operation.

LED FUNCTIONALITY

LED's have three operational states:

Steady ON
Steady OFF
Blinking

Condition: GREEN = BLINKING

RED = Steady OFF

Meaning: Module is processing data.

Condition: GREEN = Steady ON

RED = Steady ON

Meaning: 1) Configuration data is not loaded in module memory. -OR- 2) During module re-configuration both LED's are normally ON indicating data is being properly transferred to or from module memory.

Condition: GREEN = BLINKING

RED = BLINKING

Meaning: The measured input signal is outside the modules configured range. When the signal is within configured range the LED's indicate normal operation.

All other combinations indicate the module is not operating correctly.

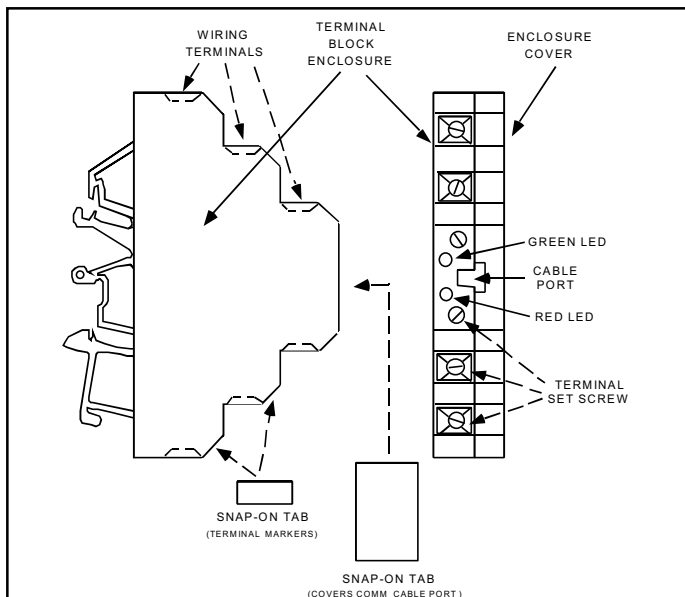

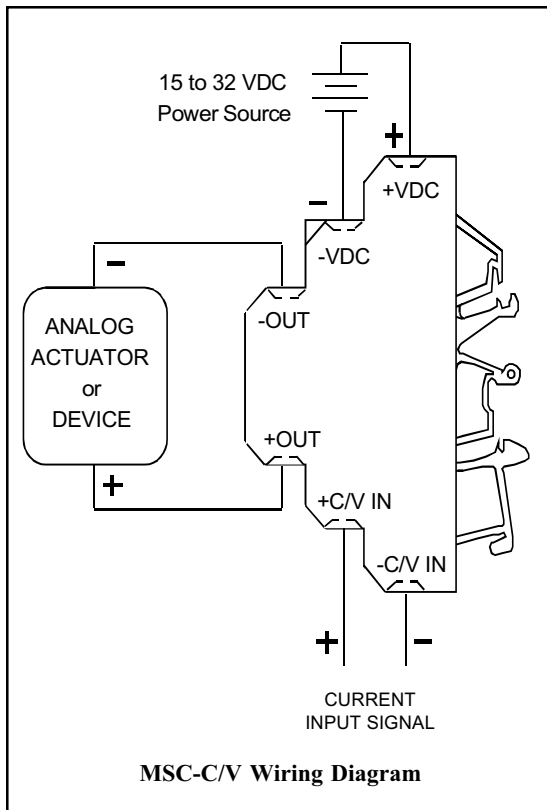

MSC-C/V Wiring Diagram

Warning: Initial power-up requires a minimum of 15Vdc and a maximum of 32Vdc. Any voltage outside this range will cause damage to the unit. When installing or servicing the unit, take precautionary steps in preventing any electrostatic discharge to the unit.

Caution: The torque specification for tightening the wire terminal set screws is 2.0 in/lb. Any torque greater than this will cause damage to the unit.

TRADE SECRETS AND PROPRIETARY NOTICE -- This document and the software described therein contains valuable trade secrets and proprietary information of SensorPulse Corp. and are copyrighted with all rights reserved. Under the copy righted laws, this document and the driver software supplied by SensorPulse Corp. may not be copied, in whole or part, without the written consent of SensorPulse Corp., except in the normal use of the software or to make a backup copy. The same proprietary and copyright notices must be affixed to any copies to be made for others, whether or not sold, given, or loaned to another person. Under the law, copying includes translating to another language or format.

SensorPulse Corp., in developing this product and drivers for applicable programmable logic controllers has attempted to offer the most current, correct and clearly expressed information possible. Nonetheless, errors can occur. Except as expressly set forth above, SensorPulse Corp. does not warrant that driver software is free from bugs, errors, or other application limitations.

WARRANTY -- Manufacturer (SensorPulse Corp.) warrants that its product, under normal use and specified use, is free from defects and poor workmanship for a period of twelve (12) months from the date of shipment from the SensorPulse factory. SensorPulse makes no other warranties or representations express or implied, whether of merchantability, suitability of fitness for a particular purpose or otherwise

SensorPulse quality products were designed, and are manufactured with tight tolerance specifications. Any attempt to repair or otherwise modify SensorPulse products will result in the termination of all warranty benefits. Although SensorPulse may choose to repair a product returned under warranty, it will not attempt to repair products that are beyond the warranty period. Evaluation and repair costs of product beyond the warranty period would likely exceed replacement costs. As such, SensorPulse supports the policy of "repair by replacement".

RETURNING MATERIAL TO THE MANUFACTURER -- Should it become necessary to return any material to the manufacturer (SensorPulse Corp.), a Return Authorization (RA) number must first be obtained. Telephone SensorPulse at 800-447-5900 or 508-230-9000 or Fax 508-230-9090 to request an RA#. Be prepared to: (1) Identify the material to be returned (model, S/N, sales order#); (2) Detail the reason for the return; (3) Describe the "next step" expectations from SensorPulse; (4) Provide a Purchase Order, if a replacement is requested prior to the receipt of the return -- even if it is believed that the return is covered under warranty.

When returning material to SensorPulse, the RA# must be included on all shipping documents and prominently displayed on the outside of the shipping container -- this will reduce your turn around time.

LIMITATION OF LIABILITY -- Buyer and/or end users sole remedy shall be the repair or replacement of the defective product with any damages limited to the purchase price of the product. In no event shall manufacturer have any liability for the direct, indirect, special, consequential or incidental damages, including but not limited to loss of profits, use or production, or for another claim for damages whether based or claimed in contract, warranty, negligence, strict liability, indemnification or otherwise.

COPYRIGHT NOTICE -- This document and the accompany driver software diskette(s) are Copyright 1995 - 1997 by SensorPulse Corp.. All right reserved. The software described in document is furnished as-is.

TRADEMARK ACKNOWLEDGMENTS -- SensorPulse, MSC, MSP, ESP, OPEN I/O, and SIGNAL I/O are registered trademarks of SensorPulse Corp. Patent No. 5,416,480. Windows/PC and Windows/CE HPC are registered trademarks of Microsoft Corp. Other products are trademarks of their respective trademark holders.

F.C.C. STATEMENT -- This equipment has been tested and found to comply with the limits for a Class B digital device, pursuant to part 15 of the FCC Rules. These limits are designed to provide reasonable protection against harmful interference in a residential installation. This equipment generates, uses and can radiate radio frequency energy and, if into installed and used in accordance with the instructions, may cause harmful interference to radio communications. However, there is no guarantee that interference will not occur in a particular installation. If this equipment does cause harmful interference to radio or television reception, which can be determined by turning the equipment off and on, the user is encouraged to correct the interference by one or more of the following measures: (1) Reorient or relocate the receiving antenna; (2) Increase the separation between the equipment and receiver; (3) Connect the equipment into an outlet on a circuit different from that to which the receiver is connected; (4) Consult the dealer or an experienced radio/TV technician for help.

INSTALLATION AND SAFETY GUIDANCE NOTES

Environment - SensorPulse Corp. products are designed to operate reliably and safely in their specified environment. However the following guidelines must be followed to ensure Safety, Electromagnetic Compatibility and Performance.

- Products have been tested for the Industrial Environment (BS EN 50081-2 and 50082-2) unless otherwise stated. Operation in any other environment is not guaranteed and at the risk of the User.
- The User is required to suppress high energy transients, such as those caused by lightning strikes, unless the product is specified for such purposes. Non-resistive loads and contact arcing must be suppressed at source.
- Products are intended for installation inside an equipment cabinet or suitable enclosure unless otherwise specified. This should be accessible only to qualified personnel during commissioning and maintenance. Open chassis products for use above 50V should only be accessible by the removal of a cover using a key or tool.
- Anti-static precautions and conventional Instrumentation best practice must always be observed. Each active module should be protected by a suitably rated fuse or equivalent protection device.

Product EMC Performance - The performance of SensorPulse Corp. products that fall within the scope of the EMC directive will meet the requirements of the relevant performance criteria as determined by the particular tests listed in the EMC standards. Products may temporarily be affected by the application of some electromagnetic disturbances but will return to published specification thereafter. Individual product details on request.

Directives - SensorPulse Corp. products are intended for installation by qualified personnel into a larger piece of equipment or system and are not accessible by the operator or that equipment or system under normal use. They do not contain any moving parts as defined by the Machinery Directive and do not fall within the scope of either the Machinery Directive or the Low Voltage Directive unless otherwise stated. The responsibility for the final equipment or system lies with the builder of that equipment or system. It is the duty of the system designer or installation engineer to ensure that our products are used in accordance with our instructions and that current safety, wiring and other relevant regulations are followed.



CONFIGURATION CHANGE

An MSC's configuration can only be changed through use of a personal computer running our Windows® based SignalFlex™ Configurator Utility and a special MSF Configuration Cable to interface the MSC unit and personal computer together. (See Requirements - on reverse side of purchasing information.)

Instructions on how to accomplish configuration change are included with SignalFlex™ Configuration Utility and not covered here.

SPECIFICATIONS

Input Power: 15-32Vdc
 Isolation: 3 way input, output and power, 1500V rms
 Step Response 10 to 90% of full scale: 0.3 seconds
 Operating Temp.: -40 to +75°C
 Storage Temp.: -40 to +85°C
 Mounting: 32 and 35mm DIN Rail & G Rail
 Dimensions: 75mm H X 12.2mm W X 60 mm D (2.95" X 0.485" X 2.5"), 24 modules can be installed per linear foot of DIN Rail
 Diagnostics LEDs: Active and alarm indications
 Maximum Wire Size: 14 AWG
 Torque for wiring to terminal set screws: 2.0 in/lb Max.
 Input Type: Current
 Input Range: (Fully scalable to user input specifications)

Current Input:
 0 to 20mA ±10mA
 0 to 10mA ±20mA
 4 to 20mA
 Accuracy: ±0.05% of full scale
 Output:
 Voltage: 0 to 5V 0 to 10V
 ±5V ±10V
 1 to 5V

For order entry, application, or customer service assistance, call toll-free 800-447-5900

All Prices and Specifications subject to change without notice

SensorPulse Corp.

120 Hupp Road Building R-6-4
 Kingsbury, IN 46345
 Phone: (800) 447-5900 / (219) 393-7218
 Fax: (219) 393-7318