

MSP OPEN I/O Family

Model MSP-V-OUT Single Channel Module

NOTE: THIS IS A FACTORY CONFIGURED UNIT

FACTORY CONFIGURATION

This MSP-V-OUT unit is factory configured and calibrated for the output voltage range printed on the MSP unit's side-label. It may be interfaced with any programmable logic controller (PLC) having one (1) +24Vdc discrete output.

An MSP-V-OUT unit can present at its OUTPUT a VOLTAGE signal spanning one of two possible ranges: 0 to 5V or 0 to 10V. The initial output range was configured by the factory. This MSP unit may be reconfigured by a user through use of SensorPulse's optional SignalFlex™ Configuration Package.

An MSP unit may be reconfigured by a user at any time via their personal computer (PC) or handheld personal computer (HPC) by installing SensorPulse Corp.'s Windows®/PC or Windows®/CE HPC based SignalFlex™ Configurator Utility, interfacing the MSP unit to the computer's RS-232C comm port with an MSF Configuration Cable (sold separately), and changing the unit's configuration settings.

OPERATIONAL DESCRIPTION

The MSP family of single channel analog I/O modules permits most any analog sensor or actuator (depending upon MSP model type) to be used with any model of PLC (even a PLC without analog capability). Each MSP model (input or output) supports one (1) analog signal-type and provides one (1) interface channel with the PLC. The MSP family includes models which provide an analog INPUT to a PLC while other models supply an analog OUTPUT from a PLC.

Communication between MSP unit and PLC is via patented 'single-wire' communication protocol. Supplied with each MSP unit are input and/or output PLC drivers pre-written for the more popular models of major PLC manufacturers. These drivers, written utilizing the programming software of their respective PLC manufacturer, are supplied on diskette and may be cut and pasted into PLC memory.

MSP models may be purchased with a factory pre-set configuration for plug-n-play application or available unconfigured so user may configure the unit to meet their unique need.

Analog world output signal via MSP unit interfaced to PLC - A small ladder logic program loaded into the PLC is used to generate patented single wire digital data transmission between PLC and MSP unit. A numerical value representing the desired analog output signal value (control variable) is placed into a PLC working register of your choice by PLC program. This value is trans-

mitted serially (one bit at-a-time) at 24 VDC signal levels to the MSP unit via the PLC's discreet I/O port. At the MSP unit the received value is scaled and/or linearized as required and the result used to generate an appropriate analog signal type at the specific value level (determined by the value from the PLC). This analog signal value is applied to the analog actuator wired to the MSP unit's output.

REQUIREMENTS

Mandatory:

- PLC with one (1) +24VDC discrete output
- THHN, MTW or other stranded interface wire to interface MSP unit with PLC I/O
- 15 - 32VDC, 50mA external supply voltage
- PLC Driver Software (supplied with unit)
- Personal or Handheld computer with Windows®/PC or Windows®/CE - to input PLC driver to PLC
- PLC to Personal/Handheld computer communication interface cable

Optional:

- SignalFlex™ Configuration Package (Part No. MSF-CC-A1) Package consists of: SignalFlex™ Configurator Utility and MSF Configuration Cable.

INSTALLATION

PLC Driver:

1. Insert 'MSP Software' diskette into desired drive of personal or handheld personal computer.
2. Access the drive containing the diskette.
3. Double click-on the 'install.bat' icon. All diskette programs will be unpacked and installed within a directory/folder labeled 'sp' at the root of your PC/HPC.
4. Remove 'MSP Software' diskette from computer.



5. Connect personal or handheld personal computer to PLC programming (comm) port.
6. Select appropriate PLC driver from within 'sp' folder on PC/HPC and copy it to your PLC's program. Then within the PLC's program change the newly installed driver's 'default addresses' to desired real-time addresses.

Hardware: See wiring diagram on reverse side

1. Mount MSP unit on standard TS32 or TS35 DIN-rail.
2. Connect external 15 to 32VDC power source to MSP Unit:
Power Positive (+) to Term: +VDC
Power Negative (-) to Term: -VDC
3. Connect output analog device to MSP Unit:
Device Voltage (+) to Term: V OUT+
Device Voltage (-) to Term: COM
4. Connect MSP unit to desired PLC Output point:
PLC Output Point to Term: PLC OUTPUT
5. If PLC has "Sinking Outputs" install a 1KW resistor between terminals PLC OUTPUT and +VDC of the MSP Unit.

CONFIGURATION CHANGE

An MSP's configuration can only be changed through use of a personal computer running our Windows® based SignalFlex™ Configurator Utility and a special configuration communication cable to interface the MSP unit and personal computer together. (See Requirements - on reverse side for purchasing information.)

Instructions on how to accomplish configuration change are included with SignalFlex™ Configuration Package and not covered here.

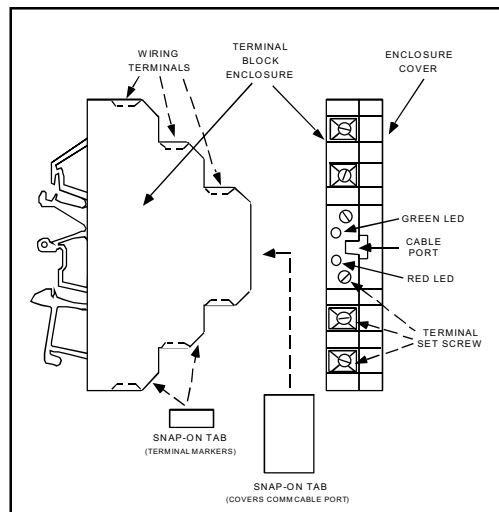

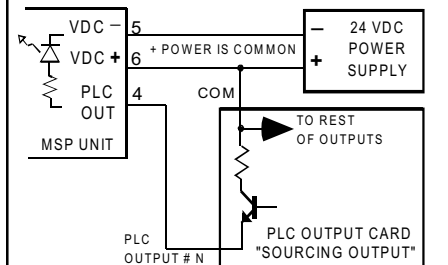
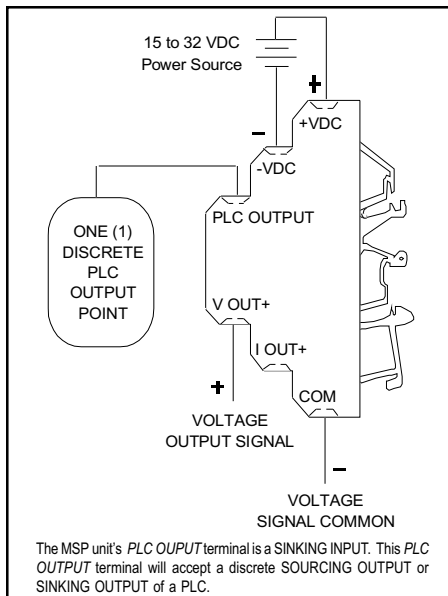

By default all drivers written by SensorPulse are written for a PLC with SOURCING OUTPUT if available. Refer to *Tech Note* that comes with the PLC Driver being used for additional information.

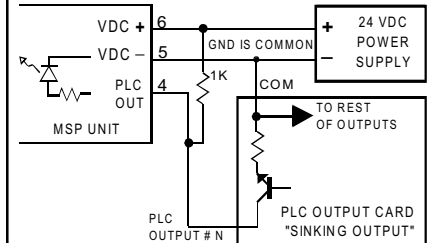

A PLC with SINKING OUTPUT will require installing a pull-up resistor and usually an edit to ladder logic of the PLC driver in use. With a PLC's SINKING OUTPUT the actual 'signal sense' is inverted from that produced the ladder logic of PLC driver (i.e., opposite that of a PLC with SOURCING OUTPUT). Refer to the *Tech Note* that comes with the PLC Driver being used for additional information.

MSP-V-OUT Wiring Diagram

FACTORY CONFIGURATION SETTINGS

PLC Interface:	
Type:	DELTA Protocol
Scan Time:	10 mil-Seconds
Full Word Bit-Count:	16
DELTA Word Bit-Count:	4
DELTA Refresh:	16
PLC Timing:	
ID Pulse Width:	3
DATA Pulse Width:	3
General:	
Watch-Dog Timer:	OFF
Filter Frequency:	60Hz

DIAGNOSTIC TOOLS

Two LEDs one RED and one GREEN are located on the front face of the MSP's enclosure and provide user with visual indication as to unit operation.

LED FUNCTIONALITY

LED's have three operational states:

Steady ON

Steady OFF

Blinking

Condition: GREEN = BLINKING

RED = Steady OFF

Meaning: Unit is processing data

Condition: GREEN = Steady ON

RED = Steady ON

Meaning: Unit is off-line with PLC due to -

- 1) Unit is uploading information from onboard memory
- 2) Unit is downloading information to onboard memory
- 3) No configuration data is available in onboard memory

Condition: GREEN = BLINKING

RED = BLINKING

Meaning: Unit is processing data but data is outside of configured range

All other combinations indicate the unit is not operating correctly.

Warning: Initial power-up requires a minimum of 15Vdc, and a maximum 32Vdc. Any voltage outside this range will cause damage to the unit. When installing or servicing the unit, take the precautionary steps in preventing any electrostatic discharge to the unit.

Caution: The torque specification for tightening the wire terminal set screws is 2.0 in/lb. Any torque greater than this will cause damage to the unit.

SPECIFICATIONS

Input Power: 15-32Vdc
 Isolation: 2 way output to input/power 1500V rms
 Update Speed: 0.1 to 0.5 seconds (PLC dependant)
 Operating Temp.: -40 to +75°C
 Storage Temp.: -40 to +85°C
 Mounting: 32 and 35mm DIN Rail & G Rail
 Dimensions: 75mm H X 12.2mm W X 60 mm D (2.95" X 0.485" X 2.5"), 24 modules can be installed per linear foot of DIN Rail
 Diagnostics LEDs: Active and alarm indications
 Maximum Wire Size: 14 AWG
 Torque for wiring to terminal set screws: 2.0 in/lb Max.
 Output Signal Type: Voltage
 Output Range: 0 to 5 V
 0 to 10 V
 Accuracy: ±0.05% of full scale
 Input: Serial Pulses from PLC Output Point

TRADE SECRETS AND PROPRIETARY NOTICE -- This document and the software described herein contains valuable trade secrets and proprietary information of SensorPulse Corp. and are copyrighted with all rights reserved. Under the copyright laws, this document and the driver software supplied by SensorPulse Corp. may not be copied, in whole or part, without the written consent of SensorPulse Corp., except in the normal use of the software or to make a backup copy. The same proprietary and copyright notices must be affixed to any copies to be made for others, whether or not sold, given, or loaned to another person. Under the law, copying includes translating to another language or format.

SensorPulse Corp., in developing this product and drivers for applicable programmable logic controllers has attempted to offer the most current, correct and clearly expressed information possible. Nonetheless, errors can occur. Except as expressly set forth above, SensorPulse Corp. does not warrant that driver software is free from bugs, errors, or other application limitations.

WARRANTY -- Manufacturer (SensorPulse Corp.) warrants that its product, under normal use and specified use, is free from defects and poor workmanship for a period of twelve (12) months from the date of shipment from the SensorPulse factory. SensorPulse makes no other warranties or representations express or implied, whether of merchantability, suitability of fitness for a particular purpose or otherwise

SensorPulse quality products were designed, and are manufactured with tight tolerance specifications. Any attempt to repair or otherwise modify SensorPulse products will result in the termination of all warranty benefits. Although SensorPulse may choose to repair a product returned under warranty, it will not attempt to repair products that are beyond the warranty period. Evaluation and repair costs of product beyond the warranty period would likely exceed replacement costs. As such, SensorPulse supports the policy of "repair by replacement".

RETURNING MATERIAL TO THE MANUFACTURER -- Should it become necessary to return any material to the manufacturer (SensorPulse Corp.), a Return Authorization (RA) number must first be obtained. Telephone SensorPulse at 800-447-5900 or 508-230-9000 or Fax 508-230-9090 to request an RA#. Be prepared to: (1) Identify the material to be returned (model, S/N, sales order#); (2) Detail the reason for the return; (3) Describe the "next step" expectations from SensorPulse; (4) Provide a Purchase Order, if a replacement is requested prior to the receipt of the return -- even if it is believed that the return is covered under warranty.

When returning material to SensorPulse, the RA# must be included on all shipping documents and prominently displayed on the outside of the shipping container -- this will reduce your turn around time.

LIMITATION OF LIABILITY -- Buyer and/or end users sole remedy shall be the repair or replacement of the defective product with any damages limited to the purchase price of the product. In no event shall manufacturer have any liability for the direct, indirect, special, consequential or incidental damages, including but not limited to loss of profits, use or production, or for another claim for damages whether based or claimed in contract, warranty, negligence, strict liability, indemnification or otherwise.

COPYRIGHT NOTICE -- This document and the accompany driver software diskette(s) are Copyright 1995 - 1997 by SensorPulse Corp.. All right reserved. The software described in document is furnished as-is.

TRADEMARK ACKNOWLEDGMENTS -- SensorPulse, MSC, MSP, ESP, OPEN I/O, and SIGNAL I/O are registered trademarks of SensorPulse Corp. Patent No. 5,416,480. Windows/PC and Windows/CE HPC are registered trademarks of Microsoft Corp. Other products are trademarks of their respective trademark holders.

F.C.C. STATEMENT -- This equipment has been tested and found to comply with the limits for a Class B digital device, pursuant to part 15 of the FCC Rules. These limits are designed to provide reasonable protection against harmful interference in a residential installation. This equipment generates, uses and can radiate radio frequency energy and, if into installed and used in accordance with the instructions, may cause harmful interference to radio communications. However, there is no guarantee that interference will not occur in a particular installation. If this equipment does cause harmful interference to radio or television reception, which can be determined by turning the equipment off and on, the user is encouraged to correct the interference by one or more of the following measures: (1) Reorient or relocate the receiving antenna; (2) Increase the separation between the equipment and receiver; (3) Connect the equipment into an outlet on a circuit different from that to which the receiver is connected; (4) Consult the dealer or an experienced radio/TV technician for help.

INSTALLATION AND SAFETY GUIDANCE NOTES

Environment - SensorPulse Corp. products are designed to operate reliably and safely in their specified environment. However the following guidelines must be followed to ensure Safety, Electromagnetic Compatibility and Performance.

- Products have been tested for the Industrial Environment (BS EN 50081-2 and 50082-2) unless otherwise stated. Operation in any other environment is not guaranteed and at the risk of the User.
- The User is required to suppress high energy transients, such as those caused by lightning strikes, unless the product is specified for such purposes. Non-resistive loads and contact arcing must be suppressed at source.
- Products are intended for installation inside an equipment cabinet or suitable enclosure unless otherwise specified. This should be accessible only to qualified personnel during commissioning and maintenance. Open chassis products for use above 50V should only be accessible by the removal of a cover using a key or tool.
- Antistatic precautions and conventional Instrumentation best practice must always be observed. Each active module should be protected by a suitably rated fuse or equivalent protection device.

Product EMC Performance - The performance of SensorPulse Corp. products that fall within the scope of the EMC directive will meet the requirements of the relevant performance criteria as determined by the particular tests listed in the EMC standards. Products may temporarily be affected by the application of some electromagnetic disturbances but will return to published specification thereafter. Individual product details on request.

Directives - SensorPulse Corp. products are intended for installation by qualified personnel into a larger piece of equipment or system and are not accessible by the operator or that equipment or system under normal use. They do not contain any moving parts as defined by the Machinery Directive and do not fall within the scope of either the Machinery Directive or the Low Voltage Directive unless otherwise stated. The responsibility for the final equipment or system lies with the builder of that equipment or system. It is the duty of the system designer or installation engineer to ensure that our products are used in accordance with our instructions and that current safety, wiring and other relevant regulations are followed.



For order entry, application, or customer service assistance, call toll-free 800-447-5900

All Prices and Specifications subject to change without notice

SensorPulse Corp. a division of Easton Controls Inc.
 120 Hupp Road Building R-6-4
 Kingsbury, IN 46345
 Phone: 800-447-5900/219-393-7218
 Fax: 219-393-7318